

# Tundra® LTX Hydraulic Pump



Since 1948

## Reliable liquid manure transfer system from Patz.

**The Tundra® LTX Pump will go great lengths to work for you!**

- Transfers liquid manure up to 2000 ft. and pumps up to 227 GPM.
- Works well with sand or sawdust laden liquid manure.
- Moves manure through the largest diameter stainless steel cylinder in the industry.
- Automatic Reciprocating Valve (ARV) has no additional external moving parts, allowing for a smooth reversing action. ARV is a one-piece, maintenance-free design.
- Gain maximum volume efficiency with (ARV) using all the stroke of the 48" cylinder. Extended lifespan with oil lubricated seals.
- Energy Efficient – Hydraulic Power unit powers the pump using a 5 or 7-1/2 HP. motor.



**Let Patz handle  
your manure so you  
don't have to!**

**MANURESOLUTIONS**  
[www.patzcorp.com](http://www.patzcorp.com)

**FLEXIBLE PAYMENT  
PLANS AVAILABLE.  
ASK FOR DETAILS.**



# Simply designed for less maintenance and long life.

## Standard features of the Patz Tundra® LTX.

### These features give the Tundra® LTX a reliable performance.

- 1 Ideal for retro-fitting and upgrading dairy and hog operations due to its **compact footprint**.
- 2 Transfer liquid manure up to 2000 ft. through the largest diameter **stainless steel cylinder** in the industry. Can pump up to 227 GPM.
- 3 Two abrasion resisting oil lubricated urethane seals in the manure **piston** allow for maximum pumping performance and extended lifespan.
- 4 The **hydraulic cylinder** (with 3.5" bore x 48" stroke) provides pressure to draw manure into the pump chamber during upstroke, while pushing manure out during the down stroke.
- 5 Higher efficiency **spring loaded flapper valves** with a thick **neoprene seal**. Easy adjustments can be made to spring tension and quick closure with an external extension spring closing system. The intake and outlet flappers are activated by vacuum and pressure produced by manure piston.
- 6 No adjustments needed with a one piece, automatic reciprocating valve that has "plug and play" design and self-actuates.
- 7 **Flooded Inlet Kit** includes an 8" knife gate valve diameter, SCH 80 PVC pipe, which extends through the concrete wall of the reception pit/tank and attaches to the basic unit on the floor.

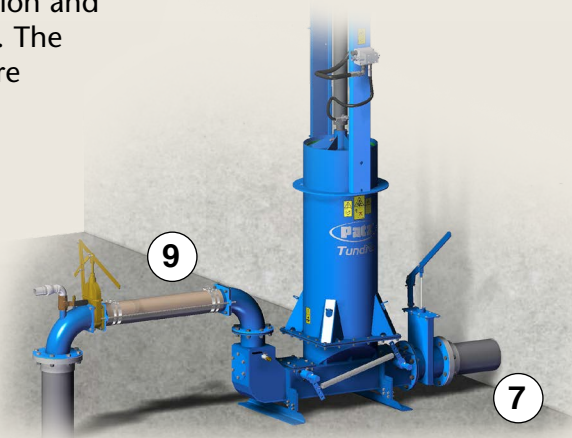

### How It Works ...

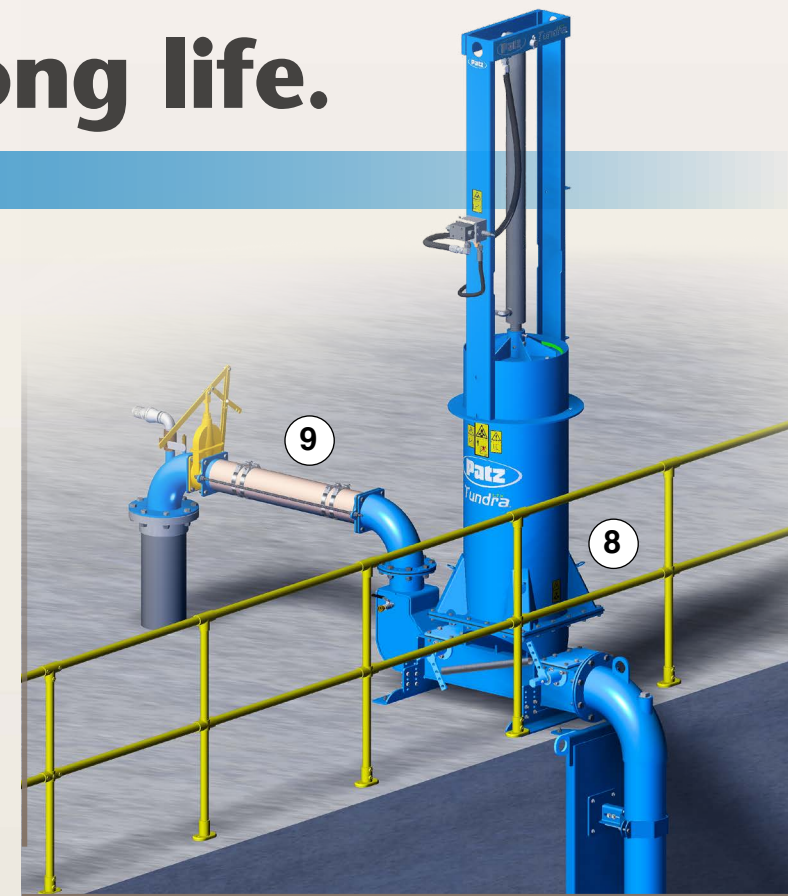
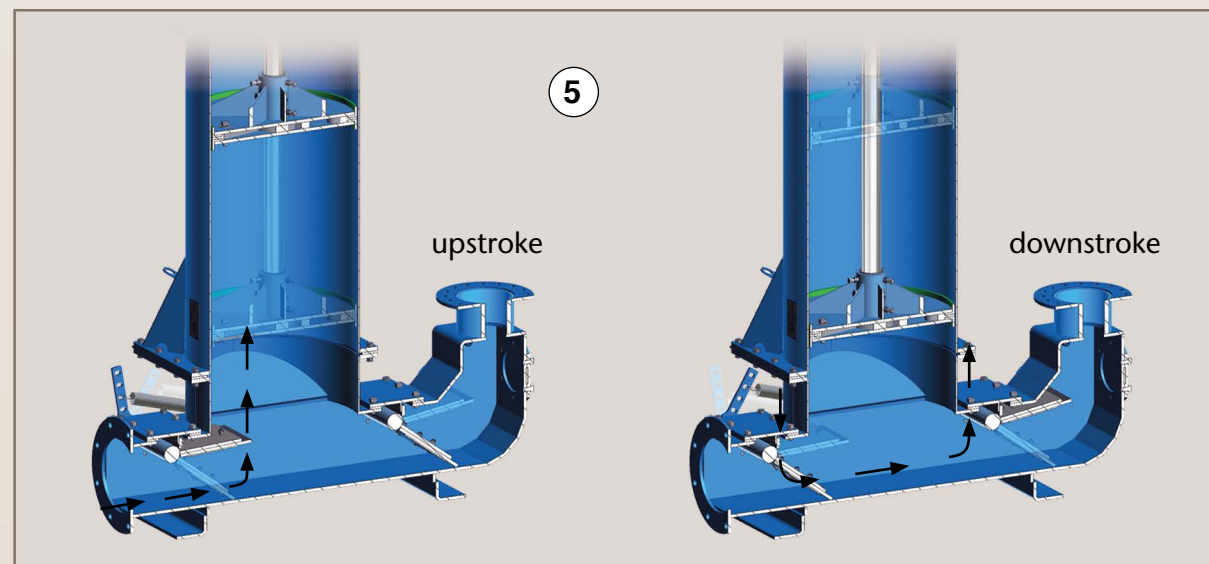

- 8 **Suction inlet kit** mounts to wall of the reception pit and attaches to the basic unit with 90° steel elbow and pipe.
- 9 **6" discharge kit**. Includes a gate valve, flexible hose, and a 90° air blow elbow.
- 10 Easy access to flapper valves for servicing/cleaning with three **service plates**. Also handy for removal of large foreign objects that may obstruct valves.
- 11 **Hydraulic power unit** uses a foot-mounted motor coupled to a gear pump to deliver hydraulic power to the Tundra® LTX. Easier installation and serviceability with this design. Works well with single or three phase 5 or 7-1/2 HP motors.



# One of many components Patz offers for your operation's manure handling system.

## Tundra® LTX Hydraulic Pump

The **Tundra® LTX Pump** is designed to transfer liquid manure with limited amounts of short bedding. Bedding can be chopped straw, sawdust, shavings, or sand. The **Tundra® LTX Pump**.

### Manure Handling System Layout

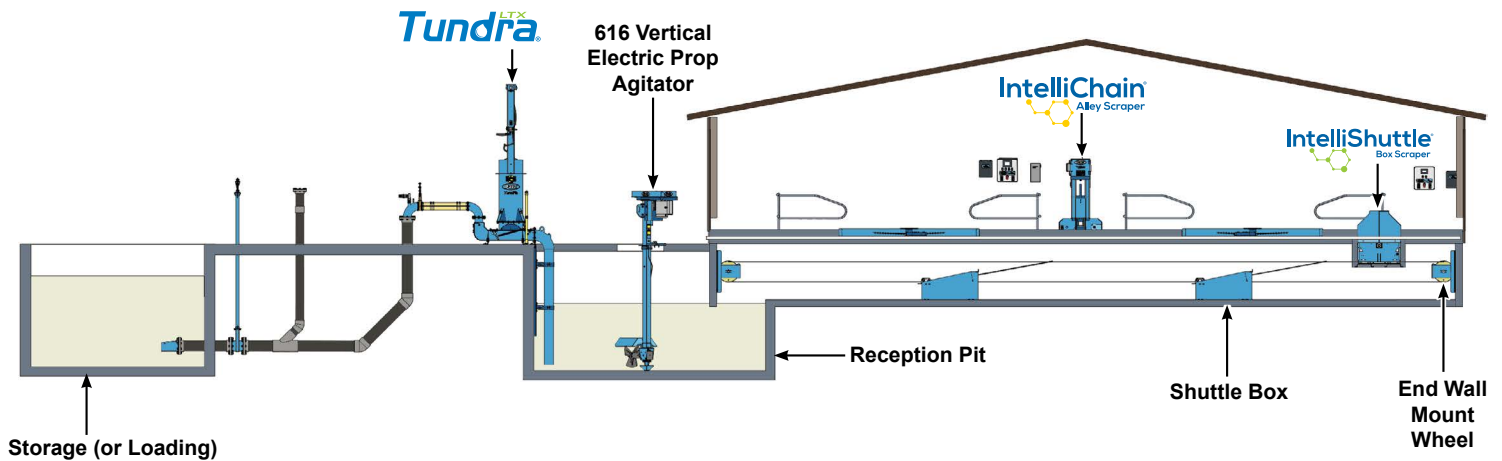

#### CONFINED SPACE PROCEDURES:

It is the responsibility of the owner/operator to comply with all local, State, Provincial or National standards, directives and industry practices regarding confined space training, education, and procedures.



**CAUTION:** Never operate Patz equipment without all shields and guards in place. Safety is no accident. Before operating any piece of equipment, be sure to read and understand the operator's manual. This manual should be kept with the machine at all times. Additionally, make sure all safety shields and devices are functioning properly and are securely in place.

For some photos in this brochure, guards were removed for photographic purposes only to allow viewing of the equipment features. Before operating equipment, all guards must be in place. Because Patz continually improves and updates products, Patz reserves the right to change the construction of machines or attachments or any part thereof without incurring any obligation to make like changes on Patz machines, or attachments previously delivered. Specifications and prices subject to change without notice.

# Patz®

Since 1948

**Proven Performance You Can Count On!**

Patz Corporation

917 Business 141, POB 7 • Pound, Wisconsin 54161-0007

Ph: (920) 897-2251 • Fax: (920) 897-2142

www.patzcorp.com • info@patzcorp.com